

# GURLEY SERIES 9x20 ROTARY INCREMENTAL ENCODER

MOTION TYPE:

ROTARY

USAGE GRADE:

INDUSTRIAL

OUTPUT:

INCREMENTAL

MAX RESOLUTION:

144,000 COUNTS/REV  
= 9 ARCSECONDS



## HIGH PERFORMANCE - INDUSTRIAL RUGGEDNESS

The Series 9x20 is a family of optical incremental encoders designed for industrial-grade applications that require high resolution and high accuracy. The Series 920 is available in two basic models and a variety of mechanical configurations. All 920s share these features:

- LED illumination for long life (100,000 hours)
- Differential photo-detectors for signal stability
- Single-board, surface-mount electronics for reliability
- RS-422 differential line driver output for noise immunity
- Zero index signal
- Sealed bearings for contamination resistance (ABEC 7 in solid shaft version; ABEC 5 in blind hollow shaft version).
- IP66 sealing for harsh environments (IP64 at the shaft exit)

**Model 9120:** Resolutions up to 4500 cycles/rev (18,000 counts/rev); optional index formats; optional input voltage.

**Model 9220:** Dual read heads for improved accuracy; monolithic integrated ASIC for internally interpolated resolutions up to 36,000 cycles/rev (144,000 counts/rev); watchdog circuit.

ingenuity<sup>®</sup>@work

ISO  
9001  
CERTIFIED

Gurley Precision Instruments  
514 Fulton Street  
Troy, NY 12180 U.S.A.  
(800) 759-1844, (518) 272-6300, fax (518) 274-0336,  
Online at [www.gurley.com](http://www.gurley.com), e-mail: [info@gurley.com](mailto:info@gurley.com)



# SPECIFICATIONS

	See Note	Model <b>9120</b>	Model <b>9220</b>
Maximum line count on disc		4500	
Maximum cycles/rev	7	4,500	36,000
Maximum counts/rev (after quadrature decode by user)		18,000	144,000
Instrument error, ± arcsec	1, 2	60	25
Quadrature error, ± electrical degrees	1, 3	30	24
Interpolation error, ± quanta	1, 4	N/A	0.1
Maximum output frequency, kHz			
1X square waves		100	100
2X square waves		N/A	150
5X square waves		N/A	300
10X square waves		N/A	500
Maximum weight, oz (g)		6 (170)	
Starting torque, in-oz (N-m) @20°C	6	<b>S:</b> 1.0 (7 x 10 <sup>-3</sup> )	<b>B:</b> 2.0 (14 x 10 <sup>-3</sup> )
Running torque, in-oz (N-m) @20°C	6	<b>S:</b> 0.5 (3.5 x 10 <sup>-3</sup> )	<b>B:</b> 1.0 (7 x 10 <sup>-3</sup> )
Moment of inertia, in-oz-s <sup>2</sup> (g-cm <sup>2</sup> )	6	<b>S:</b> 1.3 x 10 <sup>-4</sup> (9.0)	<b>B:</b> 2.9 x 10 <sup>-4</sup> (21.0)
Maximum acceleration, rad/s <sup>2</sup>		2.8 x 10 <sup>6</sup>	
Operating temperature, °F (°C)		32 to 158 (0 to 70)	32 to 122 (0 to 50)
Storage temperature, °F (°C)		0 to 160 (-18 to 71)	
Humidity, % rh, non-condensing		98	
Shock		50 g, 11 ms	
Vibration		15 g, 0-2000 Hz	
Sealing		IP66, except IP64 at the shaft exit	
Bearings	6	<b>S:</b> ABEC 7	<b>B:</b> ABEC 5 grease-lubricated and sealed
Maximum radial shaft load, lb (N)	5	25 (111)	
Bearing life (with 10 lb radial load)		1 x 10 <sup>9</sup> revolutions	

**NOTES:**

- Total Optical Encoder Error is the algebraic sum of Instrument Error + Quadrature Error + Interpolation Error. Typically, these error sources sum to a value less than the theoretical maximum. Error is guaranteed at 20°C and is defined at the signal transitions. It does not include quantization error, which is ±1/2 quantum. ("Quantum" is the final resolution of the encoder, after user's 4X quadrature decode.)
- Instrument Error is the sum of disc pattern errors, disc eccentricity, bearing runout and other mechanical imperfections within the encoder. This error tends to vary slowly around a revolution.
- Quadrature Error is the combined effect of phasing and duty cycle tolerances and other variables in the basic analog signals. This error applies to data taken at all four transitions within a cycle; if data are extracted from 1X square waves on a 1X basis (i.e., at only one transition per cycle), this error can be ignored.  
Error in arcseconds = (3600) x (error in electrical degrees) / (disc line count)
- Interpolation Error is present only when the resolution has been electronically increased to more than four data points per optical cycle. It is the sum of all the tolerances in the electronic interpolation circuitry.  
Error in arcseconds = (129600) x (error in quanta) / (counts/rev)
- The maximum recommended shaft load is based on bearing life considerations. If accuracy is critical, axial and especially radial shaft loads should be kept as low as possible.
- S = solid shaft version; B = blind hollow shaft version
- Refer to interpolation constraints table show on bottom of page 3.

## ELECTRICAL CONNECTIONS

Output Functions	Wire Colors Conn. Code <b>P</b>	Pin # DX-15P Conn. Code <b>Q</b> or <b>R</b>	Pin #DE-9P Conn. Code <b>S</b>	Pin # MS3102E-18-1P	
				Conn. Code <b>A</b>	Conn. Code <b>M</b>
<b>A</b>	Yellow	8	4	A	A
<b>/A</b>	Brown	7	8	H	B
<b>B</b>	Green	5	3	B	C
<b>/B</b>	Orange	4	7	I	D
<b>IND</b>	Blue	2	2	C	E
<b>/IND</b>	White	1	6	J	F
<b>FLT</b>	Violet	12			
<b>/FLT</b>	Gray	11			
<b>+V</b>	Red	10	5	D	I
<b>COMMON</b>	Black	13	9	F	J
<b>CASE</b>	Bare	9	1	G	H
<b>n/c</b>		3, 6,14,15		E	G

**Notes:**

- Channel B leads Channel A for clockwise shaft rotation, viewed from the shaft end.
- FLT and /FLT signals are available with **9220** only, but not with connector code **S**.
- Connector codes **A**, **S** and **M** are available with **9120S** only.



# SPECIFICATIONS

## Input Power

**9120:** +5 VDC @75 mA max. Standard;  
+12 VDC and +15 VDC available  
**9220:** +5 VDC @75 mA max.

## Output Device

On all channels: EIA/RS-422 balanced differential line driver, protected to survive an extended-duration short circuit across its output. May be used single-ended for TTL-compatible inputs.

## Index Options

**9120:** Index is available in one of three formats: ungated full cycle wide  $\pm 180^\circ$  elect;  
Half-cycle wide, gated with high state of B; or quarter-cycle wide, gated with high states of A and B.  
**9220:** Index is quarter-cycle wide, gated with high states of A and B.

## Output Waveforms (Complements omitted for clarity)

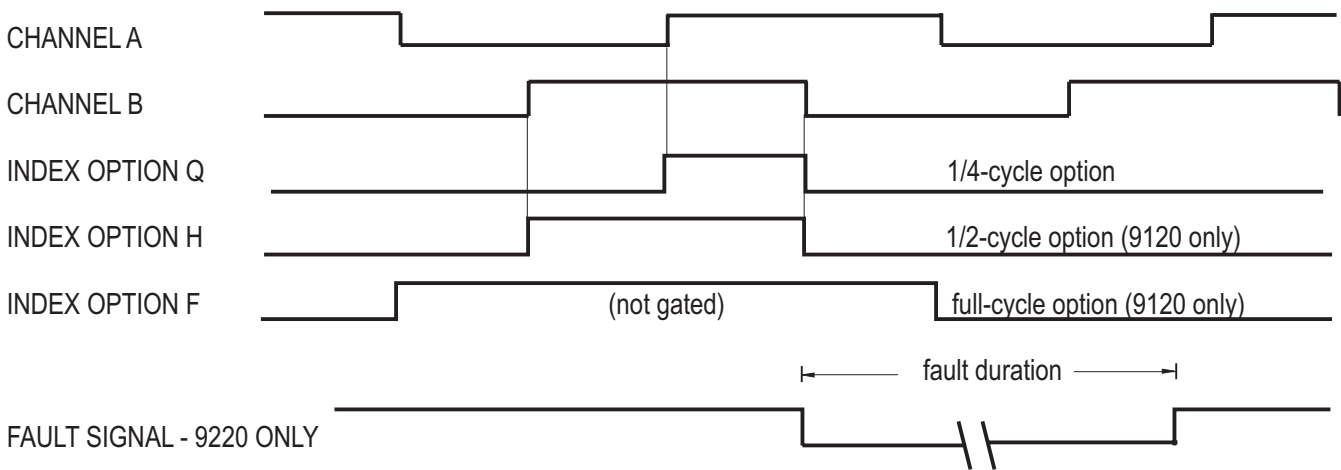

## Watchdog Circuit (model 9220 only)

If the 9220 photo-detector outputs deviate beyond prescribed limits, a FAULT pulse is issued whose duration will be for as long as the fault condition lasts.

Fault conditions detectable by this method include operation outside the specified encoder temperature range; broken or high-impedance wiring to the encoder; LED failure; low supply voltage; badly damaged bearings; defective photo-detectors; operation beyond the rated speed; and localized code disc defects such as chips, cracks or contamination.

The watchdog output provides advance warning of gradual performance degradation in cases where the failure is not sudden. This gives the user an opportunity to schedule replacement of the encoder while continuing to use it, as long as it functions correctly otherwise.

## Interpolation Constraints (9220 only)

Interpolation factor	Allowable line counts	Output cycles/rev	Max. output frequency
1X	up to 4500	up to 4,500	100 kHz
2X	1000-4500	2,000-9,000	150 kHz
5X	2500-4096	9,000-20,480	300 kHz
10X	2500-3600	25,000-36,000	500 kHz

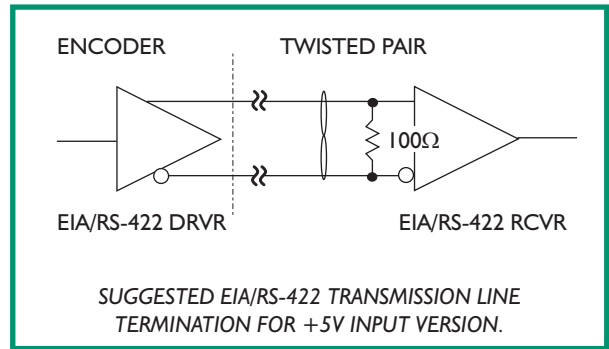

# 920 DIMENSIONS

## SERIES 920S WITH BASE CODE A

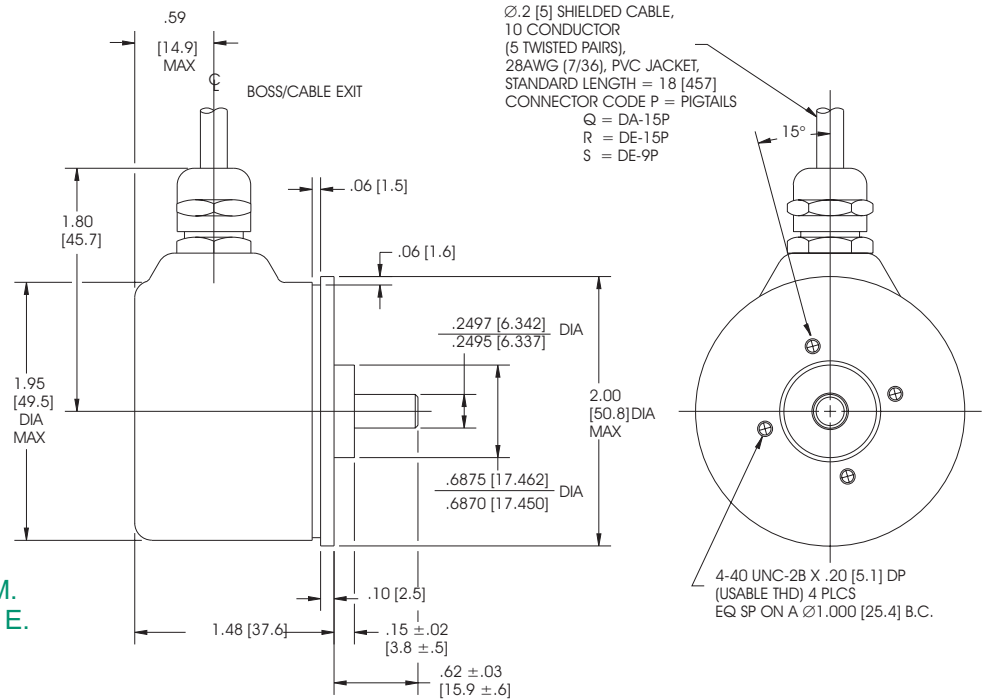

## SERIES 9120S WITH CONNECTOR CODE A OR M. USE WITH BASE CODE A,C,D OR E.

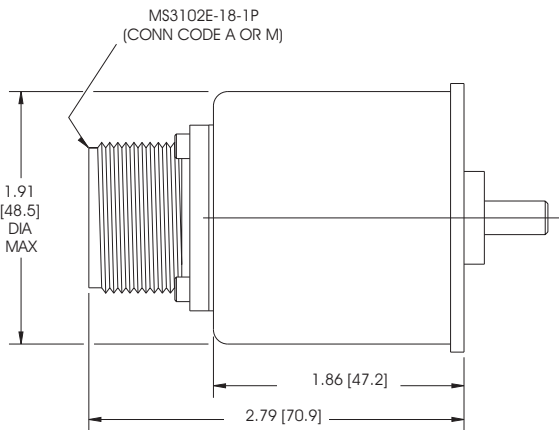

### Blind Hollow Shaft Diameter Codes, base code B or E

DIA CODE	USER'S SHAFT DIAMETER*	THREAD "B"	MAX SHAFT INTRUSION "D"
06E	0.3750 in (-.0002, -.0005)	4-40	.69 [17.5]
04E	0.2500 in	4-40	.69 [17.5]
03E	0.1875 in	4-40	.69 [17.5]
02E	0.1250 in	2-56	.51 [13.0]
10M	10.000 mm (-.005, -.013)	4-40	.69 [17.5]
08M	8.000 mm	4-40	.69 [17.5]
06M	6.000 mm	4-40	.69 [17.5]
03M	3.000 mm	2-56	.48 [12.2]

\* CONSULT FACTORY FOR OTHER SIZES

## SERIES 920B WITH BASE CODE B

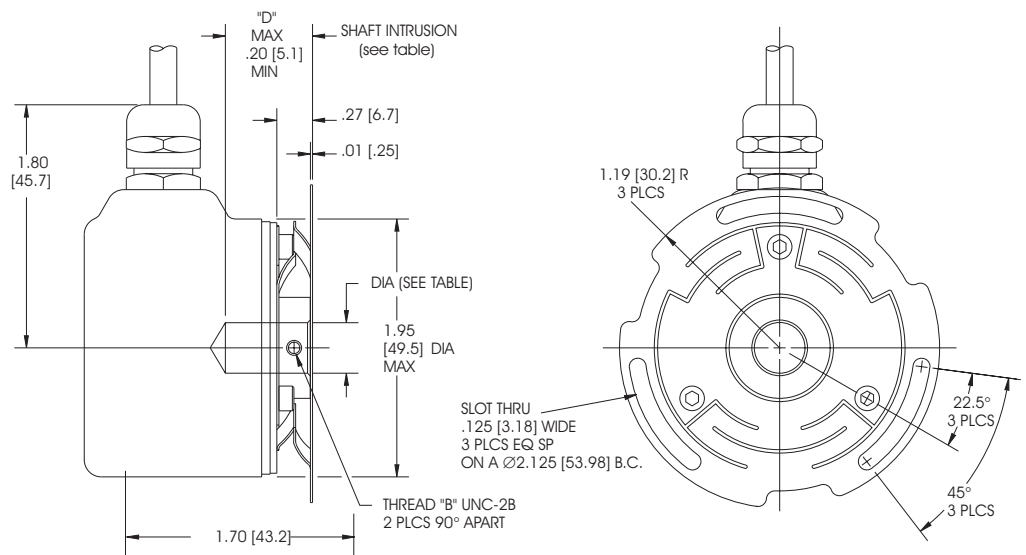

## 920S WITH BASE CODE C

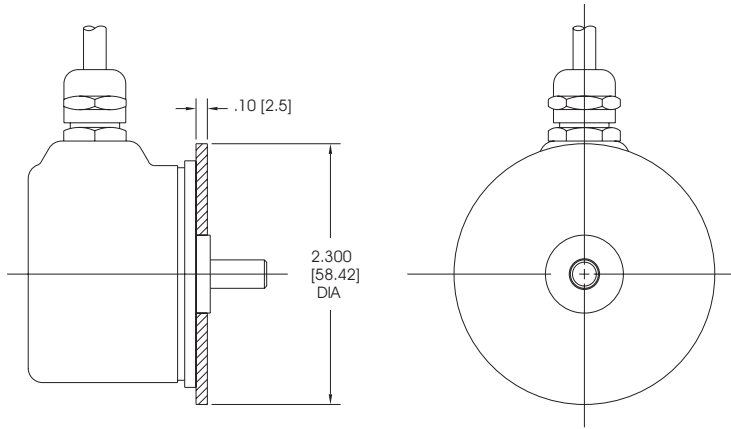

## 920S WITH BASE CODE E

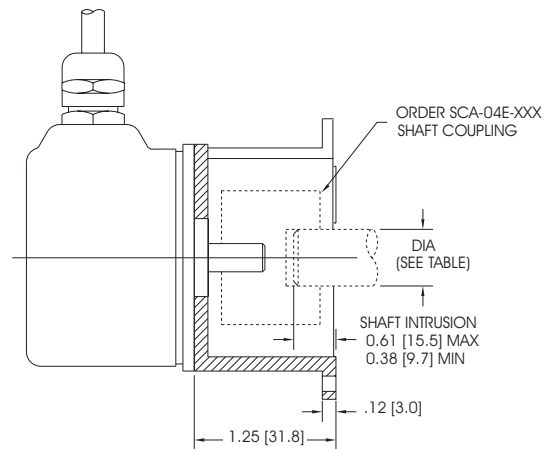

## 920S WITH BASE CODE D

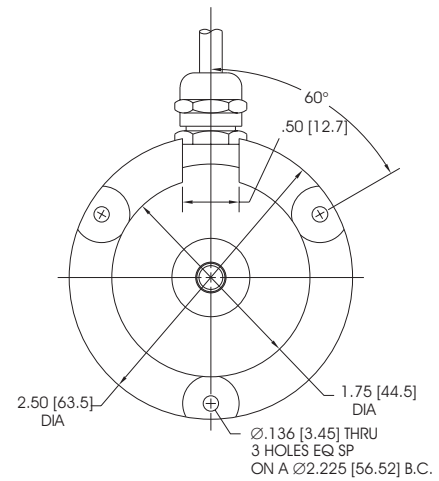
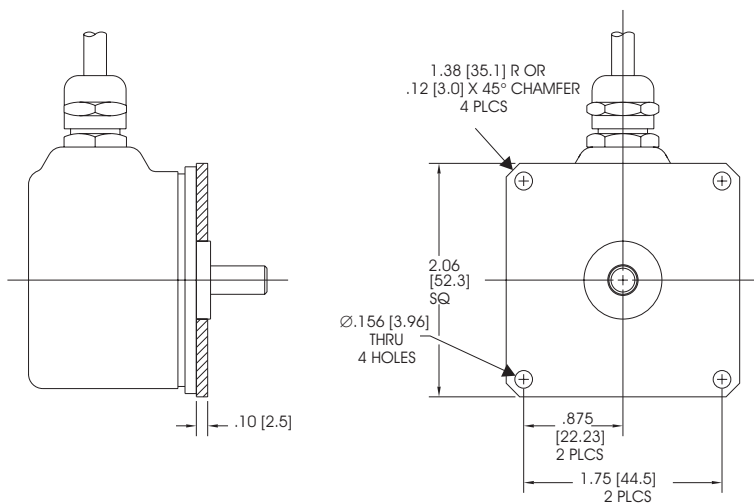

FLEXIBLE COUPLINGS	TM920AA Tether Mount (for B version)	SCA-04E Shaft Coupling (for S version)
Wind-Up, arcs/in-oz (arcs/Nm)	negligible	9.7 (1375)
Max. parallel offset, in (mm)	0.005 (0.13)	0.020 (0.5)
Max. angular misalignment	2°	1°
Max. axial extension or compression, in (mm)	0.010 (0.25)	0.020 (0.5)
Mom. of inertia, in-oz-s <sup>2</sup> (g-cm <sup>2</sup> )	n/a	4.3x10 <sup>-4</sup> (30)
Weight, oz (g)	0.13 (4)	1.0 (30)

### NOTE:

- Flexible couplings are intended to absorb normal installation misalignments and run-outs in order to prevent undue loading of the encoder bearings. To realize all the accuracy inherent in the encoder, the user should minimize misalignments as much as possible.
- Shaft coupling model number is **SCA-04E-XXE** or **-XXM**, where **XX** is taken from the DIA CODE table in the dimension drawings section.

# ORDERING INFORMATION

MODEL	SHAFT	LINES	IND	V	OUT	INTERP	BASE	CAB	EXIT	CONN	DIA	SPEC

**MODEL**

**9120**  
**9220**

**SHAFT** - Shaft type

**B** Blind hollow shaft  
**S** Solid shaft

**LINES** - Disc line count

**00500, 00512, 00900, 01000, 01024, 01800**  
**02000, 02048, 02500, 02540, 03000, 03600**  
**04096, 04500** Consult factory for other res.

**IND** - Index format

**F** Full cycle ungated (9120 only)  
**H** Half cycle gated (9120 only)  
**Q** Quarter cycle gated

**V** - Input voltage

**5** 5 volts dc  
**C** 12 volts dc (9120 only)  
**F** 15 volts dc (9120 only)

**OUT** - Output

**L** RS-422 line driver

**INTERP** - Interpolation factor

**01, 02, 05, 10**  
2x, 5x and 10x available with 9220 only

**BASE** - Base type

**A** Ø 2.0" synchro/face mount (**S** shaft type)  
**B** Tether mount (**B** shaft type)  
**C** Ø 2.3" synchro/face mount (**S** shaft type)  
**D** Square-flange mount (**S** shaft type)  
**E** Bell-flange mounts (**S** shaft type); order shaft coupling separately

**CAB** - Cable length, inches (04-99)

**18** Standard  
**00** With CONN code **A** or **M**

**EXIT** Cable exit or connector location

**S** Side (with CONN code **P, Q, R** or **S**)  
**T** Top (with CONN code **A** or **M**)

**CONN** - Connector

**P** Pigtails (no connector)  
**Q** DA-15P  
**R** DE-15P  
**S** DE-9P  
**A** MS3102E-18-1P (9120S only)  
**M** MS3102E-18-1P (9120S only)

**DIA** - Shaft diameter (see table)

**XXE** XX = sixteenths of an inch (04E = ¼")  
**XXM** XX = mm (04M = 4 mm)  
**04E** Standard with **S** shaft type

**SPEC** - Special code

**X** To define non-standard features  
**N** No special features

**Accessories** (order separately)

**SCA-04E-XXE** or **M** Shaft coupling for 920S  
**AX06399** Synchro cleats for 920S  
**M01** Mating connector for DA-15P  
**M05** Mating connector for DE-15P  
**M06** Mating connector for DE-9P  
**M02** Mating connector for MS3102E18-1P  
**ISC3N** Interface card for IBM<sup>a</sup> PC

**SPECIAL CAPABILITIES**

For special situations, we can optimize catalog encoders to provide higher frequency response, greater accuracy, wider temperature range, reduced torque, non-standard line counts, or other modified characteristics. In addition, we regularly design and manufacture custom encoders for user-specific requirements. These range from high-volume, low-cost, limited-performance commercial applications to encoders for military, aerospace and similar high-performance, high-reliability conditions. We would welcome the opportunity to help you with your encoder needs.

**WARRANTY**

Gurley Precision Instruments offers a limited warranty against defects in material and workmanship for a period of one year from the date of shipment.

