

# GURLEY MODEL R137 ROTARY INCREMENTAL ENCODER

**MOTION TYPE:**

ROTARY

**USAGE GRADE:**

LT.-MED. INDUSTRIAL

**OUTPUT:**

INCREMENTAL

**MAX RESOLUTION:**

720,00 COUNTS/REV  
(0.18 ARCSECONDS/COUNT)

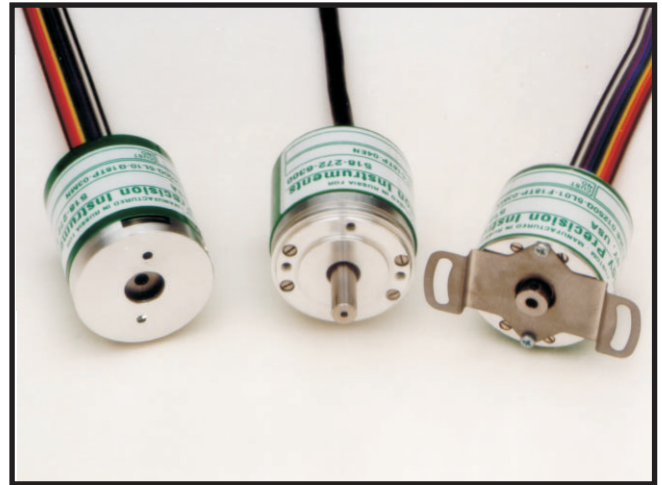

## HIGH PERFORMANCE - COMPACT PACKAGE

The Model R137 optical incremental encoder is designed for industrial-grade applications requiring high resolution in a small package. Mechanical features are as follows:

- 37 mm dia x 37 mm long body; shielded cable; sealed to IP66 (IP 64 at shaft exit).
- LED illumination for long life (>100,000 hours)
- Differential photo-detectors for signal stability
- Single-board, surface-mount electronics for reliability
- RS-422 differential line driver output for noise immunity
- Zero index signal
- Sealed bearings for contamination resistance
- Monolithic integrated ASIC for internally interpolated resolutions up to 180,000 cycles/rev (720,000 counts/rev)
- Optional Fault detection signal for resolutions of 360k & 720k counts/rev (consult factory for additional details)

ingenuity<sup>®</sup>@work

ISO  
9001  
CERTIFIED

Gurley Precision Instruments  
514 Fulton Street  
Troy, NY 12180 U.S.A.  
(800) 759-1844, (518) 272-6300, fax (518) 274-0336,  
Online at [www.gurley.com](http://www.gurley.com), e-mail: [info@gurley.com](mailto:info@gurley.com)



	See Note	Model R137
Maximum line count on disc		3600
Maximum cycles/rev (quad sq waves)		180,000
Max counts/rev (after quad decode)		720,000
Internal square wave interpolation		1X, 2X, 5X 10X, 16X, 25X or 50X (or analog output)
Instrument error, ± arcsec	1, 2	70
Quadrature error, ± electrical degrees	1, 3	24
Interpolation error, ± quanta	1, 4	0.15
Maximum output frequency, kHz		
1X square waves		100
2X square waves		150
5X square waves		300
10X, 16X square waves		500
Starting torque, N-m		0.001
Moment of inertia, in-oz-s <sup>2</sup> (g-cm <sup>2</sup> )		2.3 x 10 <sup>-5</sup> in-oz-s <sup>2</sup> (1.7 g-cm <sup>2</sup> )
Maximum acceleration, rad/s <sup>2</sup>		3 x 10 <sup>6</sup>
Operating temperature, °F (°C)		Standard is 32 to 158 (0 to 70); Extended is -40 to 212 (-40 to +85)
Humidity, % rh, non-condensing		98
Shock		50 g, 11 ms
Vibration		15 g, 0-2000 Hz
Maximum weight, oz (g)		2.7 (75)
Sealing		IP66, except IP64 at the shaft exit
Bearings		Grease-lubricated and sealed
Maximum radial shaft load, lb (N)	5, 6	2 lb (10)
Maximum axial shaft load, lb (N)		1 lb (5)

**NOTES:**

- Total Optical Encoder Error is the algebraic sum of *Instrument Error* + *Quadrature Error* + *Interpolation Error*. Typically, these error sources sum to a value less than the theoretical maximum. Error is defined at the signal transitions and therefore does not include quantization error, which is ±1/2 quantum. ("Quantum" is the final resolution of the encoder, after user's 4X quadrature decode.) Accuracy is guaranteed at 20°C.
- Instrument Error* is the sum of disc pattern errors, disc eccentricity, bearing runout and other mechanical imperfections within the encoder. This error tends to vary slowly around a revolution.
- Quadrature Error* is the combined effect of phasing and duty cycle tolerances and other variables in the basic analog signals. This error applies to data taken at all four transitions within a cycle; if data are extracted from 1X square waves on a 1X basis (i.e., at only one transition per cycle), this error can be ignored.

**Error in arcseconds = (3600) x (error in electrical degrees) / (disc line count)**

- Interpolation Error* is present only when the resolution has been electronically increased to more than four data points per optical cycle. It is the sum of all the tolerances in the electronic interpolation circuitry.

**Error in arcseconds = (1296000) x (error in quanta) / (counts/rev)**

- If higher load capacity is required, consult factory.
- S** = solid shaft version; **B** = blind hollow shaft with external tether; **C** = blind hollow shaft with internal coupling.

**FAULT DETECTION CIRCUIT**

An optional fault-detection circuit is offered that constantly monitors the encoder's internal signals. If they deviate beyond prescribed limits, an active-low signal is generated. Fault conditions detectable by this circuit include: LED light source failure or aging, defective photo-detectors, contamination of the code disc or other optical components, localized code disc defects such as chips or cracks. Consult factory for additional details.



## INPUT POWER

+5 VDC @100 mA max.

## SQUARE WAVE OUTPUT OUTPUT CODE L

Quadrature square waves at 1, 2, 5, 10 or 16 times the line count on the disc. On all channels: EIA/RS-422 balanced differential line driver, protected to survive an extended-duration short circuit across its output. May be used single-ended for TTL-compatible inputs. Index is 1/4-cycle wide, gated with the high states of channels A and B.

### OUTPUT WAVEFORMS (CW rotation shown)

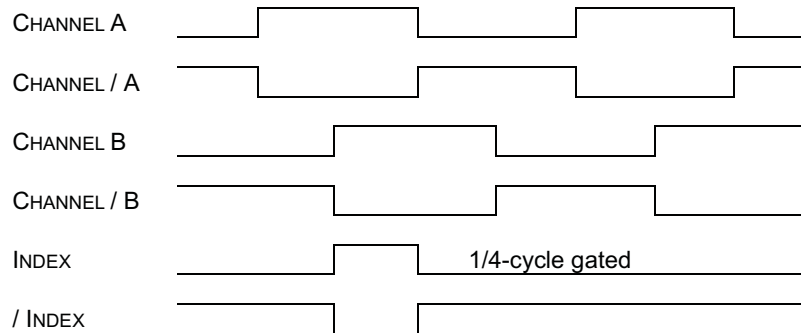

## BUFFERED SINUSOID OUTPUT OPTIONS

**OUTPUT CODE B** should be ordered when the HR2A High Resolution Interpolator will be used. (Consult factory for availability of line counts that will work with this option.) The output device is an op-amp referenced to  $(50\% \pm 3\%) \times V_{cc}$ . Typical signal roll-off at 100 kHz  $\leq 3$  dB. Signals are single-ended. Signal values at 1 kHz with 4.7 k $\Omega$  load to common

Peak-to-peak signal amplitudes, SIN and COS:	1.0 $\pm$ 0.1 V
Amplitude ratio, min channel to max channel:	0.9 to 1.0
Peak-to-peak signal amplitude, INDEX:	0.75 V
Index width @Vref:	360° $\pm$ 180°
Index peak occurs with Channel B peak	
Channel B (cos) leads Channel A (sin) for CW rotation	

**OUTPUT CODE M** should be selected for all other applications requiring analog output. The output device is an op-amp referenced to  $(50\% \pm 3\%) \times V_{cc}$ . Typical signal roll-off at 100 kHz  $\leq 3$  dB. SIN, COS and INDEX are

Peak-to-peak signal amplitudes, SIN and COS:	1.0 $\pm$ 0.1 V
Amplitude ratio, min channel to max channel:	0.9 to 1.0
Peak-to-peak signal amplitude, INDEX:	0.75 V
Index width @Vref:	300° $\pm$ 45°
Index peak occurs where Chan A+ = Chan B+ (135°)	
Channel A (sin) leads Channel B (cos) for CW rotation (standard for all R13X except Output Code B).	

## EXTENDED RESOLUTION

The R137 offers resolution up to 57,600 cycles/rev (up to 230,400 counts/rev after user's 4X quadrature decode) with internal electronics. If finer resolution is required (up to 288,000 counts/rev), the HR2A external electronics package can be used with either encoder. The HR2A can also provide interpolation factors other than 2, 5 or 10, which are available internally in the R137. The encoder must be ordered with output code B and connector code Q. (See separate HR2A data sheet for details).

**R 1 3 7**

PAGE 3 OF 7

0711

Gurley Precision Instruments

514 Fulton Street

Troy, NY 12180 U.S.A.

(800) 759-1844, (518) 272-6300, fax (518) 274-0336,

Online at [www.gurley.com](http://www.gurley.com), e-mail: [info@gurley.com](mailto:info@gurley.com)



# SPECIFICATIONS

## ELECTRICAL CONNECTIONS

	CONN CODE	P	Q	R	S
	CONN TYPE	NONE	DA-15P	DE-15P	DE-9P
	FUNCTION	COLOR	PIN #	PIN #	PIN #
Square Wave Output (output code L)	A	Yellow	8	8	4
	/A	Brown	7	7	8
	B	Green	5	5	3
	/B	Orange	4	4	7
	IND	Blue	2	2	2
	/IND	White	1	1	6
	FAULT	Violet	12	12	N/A
	/FAULT	Gray	11	11	N/A
	+V	Red	10	10	5
	COMM	Black	13	13	9
CASE	Shield	9	9	1	
Buffered Sinusoid Output (output code B)	SIN	Yellow	9		
	COS	Green	11		
	IND	Blue	5		
	+V	Red	4		
	COMM	Black	15		
CASE	Shield	8			
Buffered Sinusoid Output (output code M)	A	Yellow	8		
	/A	Brown	7		
	B	Green	5		
	/B	Orange	4		
	IND	Blue	2		
	/IND	White	1		
	+V	Red	10		
	COMM	Black	13		
CASE	Shield	9			

NOTE: Channel A leads Channel B for clockwise shaft rotation, viewed from the shaft end.

## FLEXIBLE SHAFT COUPLINGS

	External Tether Mount (for B version)	Internal Shaft Coupling (for C version)	SCA-Shaft Coupling (for S version)
Wind-up, arcs/in-oz (arcs/Nm)	Negligible	Negligible	9.7 (1375)
Max. parallel offset, in (mm)	0.003 (0.08)	0.004 (0.1)	0.020 (0.50)
Max. angular mis-alignment, degrees	2	0.5	1
Max. axial extension or compression, in (mm)	0.005 (0.13)	None	0.020 (0.50)
Moment of inertia, in-oz-s <sup>2</sup> (g-cm <sup>2</sup> )	N/A	N/A	4.3 x 10 <sup>-4</sup> (30)
Weight, oz (g)	Negligible	N/A	1.0 (30)

NOTE:

- Flexible couplings are intended to absorb normal installation misalignments and run-outs in order to prevent undue loading of the encoder bearings. To realize all the accuracy inherent in the encoder, the user should minimize misalignments as much as possible.
- Model number of the shaft coupling for **S** version (use BASE CODE **C** or **E** with 1/4" shaft dia.) is **SCA-04E-XXX**, where XXX = user's shaft diameter. Select XXX from the following table:

<b>04E</b>	1/4"
<b>05E</b>	5/16"
<b>06E</b>	3/8"
<b>08M</b>	8 mm
<b>06M</b>	6 mm
<b>10M</b>	10 mm

AVAILABILITY OF DIFFERENT SHAFT DIAMETERS (blank = not available)

BASE CODE:	A	B	C	D	E	F	G
<b>R137</b>		4 mm	1/8", 1/4"	1/8"	1/4"	3 mm	3 mm

**R137**

PAGE 4 OF 7

0711

Gurley Precision Instruments  
514 Fulton Street  
Troy, NY 12180 U.S.A.  
(800) 759-1844, (518) 272-6300, fax (518) 274-0336,  
Online at [www.gurley.com](http://www.gurley.com), e-mail: [info@gurley.com](mailto:info@gurley.com)



\*ALL DIMENSIONS IN INCHES [MM]

## MODEL R137S WITH BASE CODE B

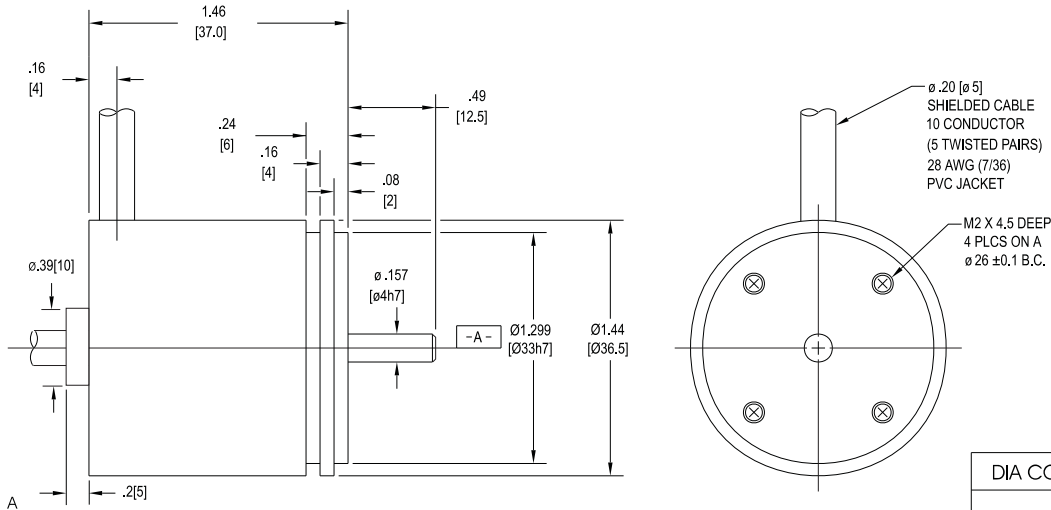

DIA CODE	D	L
02E	.1247/.1245 [3.167/3.162]	.43 [10.9]
04E	.2447/.2445 [6.342/6.337]	.63 [16.0]

## MODEL R137S WITH BASE CODE C

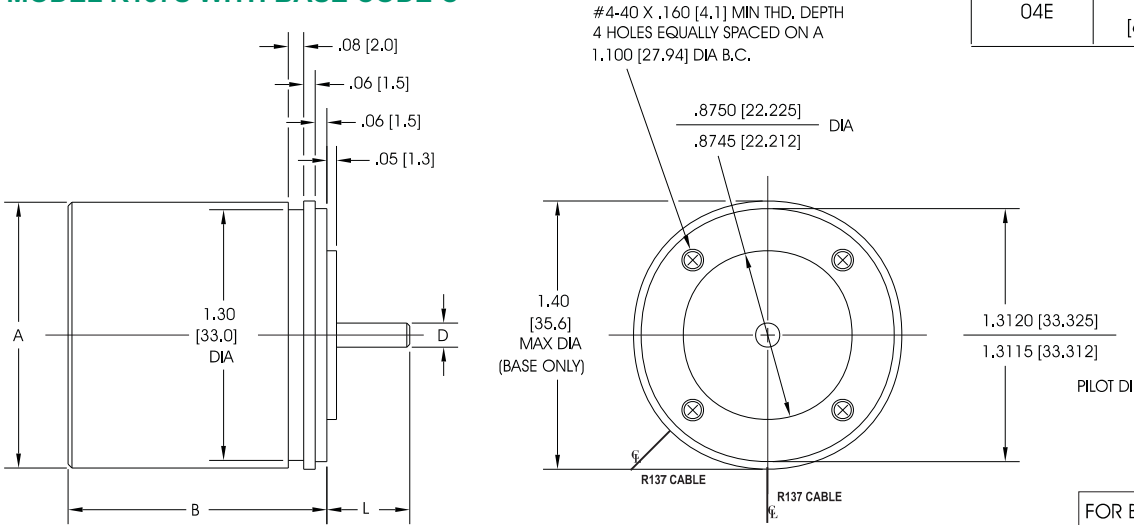

FOR BASE CODES C & D	R137
A COVER DIA	1.44 [36.5]
B LENGTH	1.46 [37.0] MAX

## MODEL R137S WITH BASE CODE D

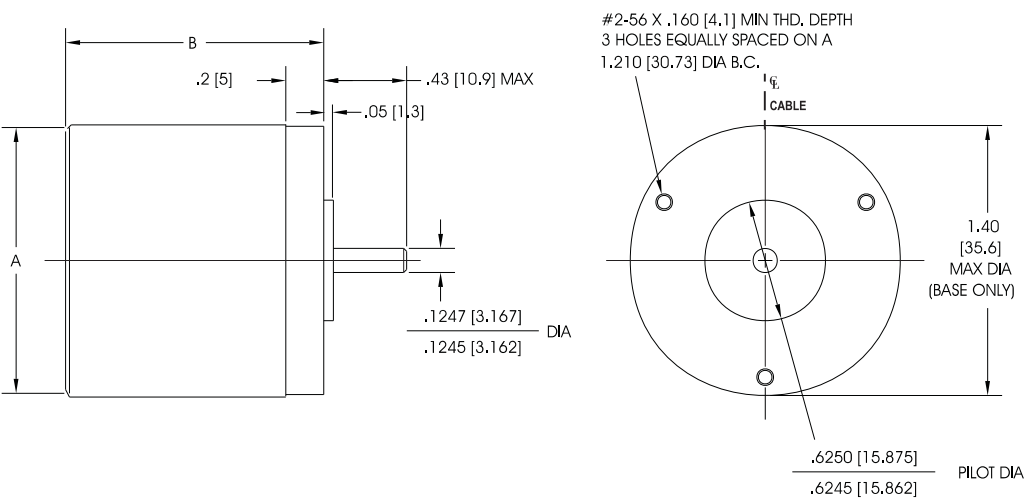

MODEL R137S WITH BASE CODE E

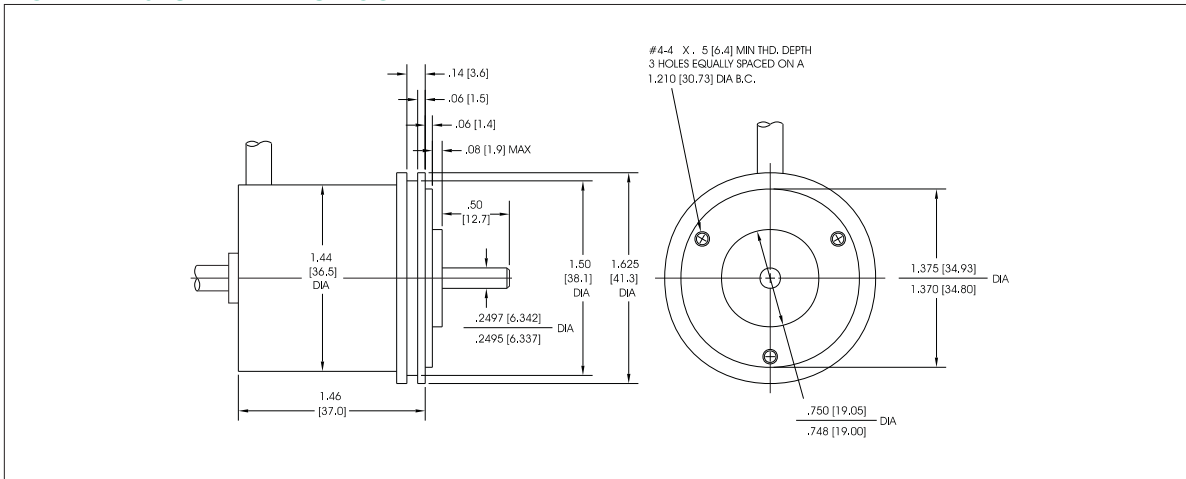

MODEL R137B WITH BASE CODE F

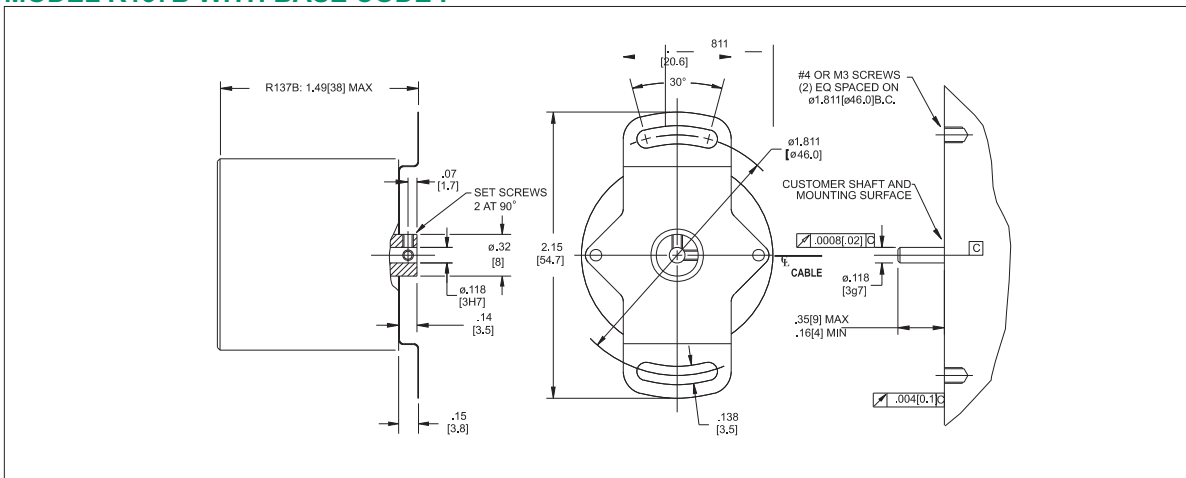

MODEL R137C WITH BASE CODE G

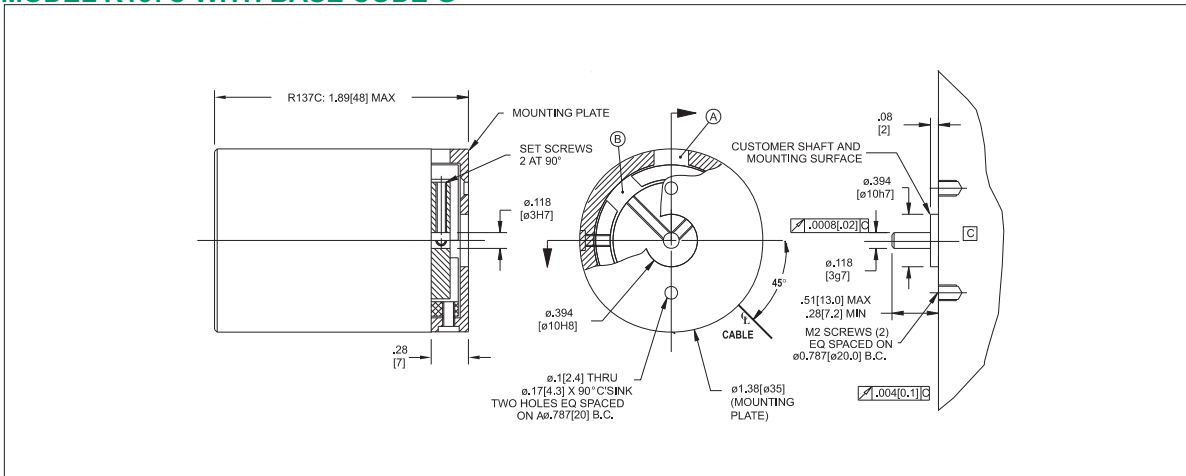

DURING INSTALLATION, THE ENCODER IS ROTATED IN RELATION TO THE MOUNTING PLATE ALIGNING SLOT "A" WITH SLOT "B" TO ALLOW ACCESS TO THE SHAFT SET SCREWS AS SHOWN IN THE SIDE VIEW

DIMENSIONS IN INCHES [MM]



# ORDERING INFORMATION

**MODEL** **SHAFT - LINES** **IND** - **OUT** **INTERP - BASE** **TEMP** **CAB** **EXIT** **CONN - DIA** **SPEC**  
    5

**MODEL**  
R137

**SHAFT** - Shaft type  
**S** Solid shaft  
**B** Blind hollow shaft (external tether)  
**C** Blind hollow shaft (internal coupling)

**LINES** - Disc line count  
**00100, 00180, 00200, 00250, 00500, 00600,**  
**00720, 00900, 01000, 01024, 01200, 01250,**  
**01500, 01800, 02000, 02048, 02500, 02540,**  
**03600**  
 Consult factory for other line counts

**IND** - Index format  
**F** Full cycle (OUT = **B** or **M**)  
**Q** Quarter-cycle gated (OUT = **L**)

**OUT** - Output format  
**B** Buffered sinusoids (single-ended)  
**M** Buffered sinusoids (differential)  
**L** RS422 Differential line driver sq. waves

**INTERP** - Interpolation factor  
**01** OUT = **B, M** or **L**  
**02, 05, 10, 16** OUT = **L**  
**25, 50** OUT = **L** with Fault Detection Circuit

**BASE** - Base type  
**B**  $\phi$ 33mm pilot, 4 M3  
**C**  $\phi$ 1.312 & 0.875 pilots, 4 #4-40  
**D**  $\phi$ 0.625 pilot, 3 #2-56  
**E**  $\phi$ 1.375 & 0.750 pilots, 3 #4-40  
**F** Blind hollow shaft with external tether  
**G** Blind hollow shaft with internal coupling  
**H** C + slotted stub shaft

**TEMP**  
**N** 0 to 70C  
**T** -40C to +85C (not avail with R137C)

**CAB** - Cable length, inches  
**18** Standard

**EXIT** - Cable exit  
**S** Side  
**T** Top

**CONN** - Connector  
**P** Pigtails (no connector)  
**Q** DA-15P  
**R** DE-15P  
**S** DE-9P

**DIA** - Shaft diameter  
**03M** 3 mm  
**04M** 4 mm  
**05M** 5 mm ("S" shaft only)  
**02E** 1/8 inch  
**04E** 1/4 inch ("S" shaft only)

**SPEC** - Special code  
**X** To define non-standard features  
**N** No special features

**Accessories** (order separately)  
**SCA-04E-XXX** Shaft coupling  
**AX06399** Synchro mounting cleats  
**M01** Mating connector for DA-15P  
**M05** Mating connector for DE-15P  
**M06** Mating connector for DE-9P  
**ISC3N** Interface card for IBM® PC

## SPECIAL CAPABILITIES

For special situations, we can optimize catalog encoders to provide higher frequency response, greater accuracy, wider temperature range, reduced torque, non-standard line counts, or other modified parameters. In addition, we regularly design and manufacture custom encoders for user-specific requirements. These range from high-volume, low-cost, limited-performance commercial applications to encoders for military, aerospace and similar high-performance, high-reliability conditions. We would welcome the opportunity to help you with your encoder needs.

## WARRANTY

Gurley Precision Instruments offers a limited warranty against defects in material and workmanship for a period of one year from the date of shipment.

**R 1 3 7**

PAGE 7 OF 7

0711

**Gurley Precision Instruments**  
 514 Fulton Street  
 Troy, NY 12180 U.S.A.  
 (800) 759-1844, (518) 272-6300, fax (518) 274-0336,  
 Online at [www.gurley.com](http://www.gurley.com), e-mail: [info@gurley.com](mailto:info@gurley.com)

